

TSXCAY21C

motion control modules - for servomotors - 8 ms..10 s - 2 axes

Product availability : Non-Stock - Not normally stocked in distribution facility

Price* : 5,571.75 USD



TSXCAY21C has not been replaced. Please contact your customer care center for more information.

⚠ Discontinued

Main

Range of product	Modicon Premium Automation platform
Product or component type	Motion control modules
Product specific application	For servo motors
Servo loop type	Proportional to overshoot compensation and gain switching 2 ms
Checks	Consistency of commands Encoder coupling, servo drive present, emergency stop Proper execution of movement Sensor power supply Validity of parameters Presence of voltage/sensor feedback counter input

Complementary

Speed profile path	Trapezoidal or parabolic
Resolution	<= 1000 position units per point >= 0.5 position units per point
Length of axis	32000...32000000 P
Acquisition speed	<= 270000 points/mn >= 54000 points/mn
Acceleration time	8 ms...10 s
Operating mode	Automatic Direct drive mode FOLLOWER Manual OFF
Type of axis	Following axis static ratio Limited axis
I/O modularity	2 axes
Input compatibility	Absolute encoder SSI output 16...25 bits Incremental encoder 10...30 V totem pole Incremental encoder 5 V DC RS422 With 2-wire/3-wire sensor (24 DC) auxiliary input Absolute encoder parallel output ABE7CPA11
Clock frequency	200 kHz SSI absolute encoder
Incremental encoder frequency x1	500 kHz
Incremental encoder frequency x 4	1000 kHz in counting

	250 kHz in input
Power dissipation in W	7.2...11.5 W
Input type	Current sink auxiliary input conforming to EN/IEC 1131 Type 2 Resistive counter input Resistive servo drive control input conforming to EN/IEC 1131 Type 1
Input logic	Positive
Input voltage	24 V 8 mA auxiliary input 24 V 8 mA servo drive control input 5 V 18 mA counter input
Input voltage limits	<= 5.5 V counter input 19...30 V auxiliary input 19...30 V servo drive control input
Voltage state 1 guaranteed	>= 11 V auxiliary input >= 11 V servo drive control input >= 2.4 V counter input
Current state 1 guaranteed	>= 3.5 mA servo drive control input >= 3.7 mA counter input >= 6 mA auxiliary input
Voltage state 0 guaranteed	<= 1.2 V counter input <= 5 V auxiliary input <= 5 V servo drive control input
Current state 0 guaranteed	<= 1 mA counter input <= 1.5 mA servo drive control input <= 2 mA auxiliary input
Input impedance	270 Ohm counter input 3000 Ohm auxiliary input 3000 Ohm servo drive control input
Number of outputs	2 analogue output static 2 reflex output static conforming to EN/IEC 61131 2 servo drive validation output relay
Analogue output range	+/- 10...24 V
Analogue output resolution	13 bits + sign
LSB value	1.25 mV analogue output
Output voltage	24 V DC reflex output 24 V DC servo drive validation output
Output voltage limits	19...30 V reflex output 5...30 V servo drive validation output
Nominal output current	0.5 A reflex output
Maximum output current	1.5 mA analogue output 200 mA servo drive validation output 625 mA reflex output
Minimum load	1 mA 1 V
Voltage drop	< 1 V at state on reflex output
Leakage current	< 0.3 mA reflex output
Switching time	< 5 ms for servo drive validation < 500 µs for reflex output
Output compatibility	Positive logic DC inputs (resistance <= 15 kOhm) reflex
Short-circuit protection	Current limiter reflex output Thermal tripping reflex output
Output overload protection	Current limiter reflex output Thermal tripping reflex output
Output overvoltage protection	Zener diode between outputs and 24 DC reflex output
Reverse polarity protection	Reverse diode on supply reflex output
Local signalling	2 LEDs green axis diagnostics available 1 LED green module operating (RUN) 1 LED red external fault (I/O) 1 LED red internal fault, module failure (ERR)
Electrical connection	1 connector HE-10 20 pins for aux inputs, reflex output, for external sensor and preactuator power supply 1 connector HE-10 20 pins for servo drive ctrl inputs + for ext power supply of servo drive inputs/ outputs 1 connector SUB-D 9 for an analogue output (speed reference) 2 connectors SUB-D 15 for an incremental or absolute encoder

Current consumption	1100 mA 5 V DC 15 mA 24 V DC 11...20 mA 24 V DC on 10/30 V absolute encoder module
Module format	Standard
Product weight	1.06 lb(US) (0.48 kg)

Environment

Protective treatment	Conformal coating Humiseal 1A33 TC
Ambient air temperature for operation	32...140 °F (0...60 °C)
Ambient air temperature for storage	-13...158 °F (-25...70 °C)
Relative humidity	5...95 % without condensation
Operating altitude	<= 6561.68 ft (2000 m)

Ordering and shipping details

Category	22558 - TSX PREMIUM, ATRIUM & PL7 PRO
Discount Schedule	PC22
GTIN	003595863959109
Nbr. of units in pkg.	1
Package weight(Lbs)	2.2000000000000002
Returnability	N
Country of origin	FR

Offer Sustainability

RoHS (date code: YYWW)	Compliant - since 0801 - Schneider Electric declaration of conformity Schneider Electric declaration of conformity
REACH	Reference not containing SVHC above the threshold Reference not containing SVHC above the threshold

Contractual warranty

Warranty period	18 months
-----------------	-----------

Standard and Extendable Racks for Modules Mounting

Dimensions of Modules and Racks

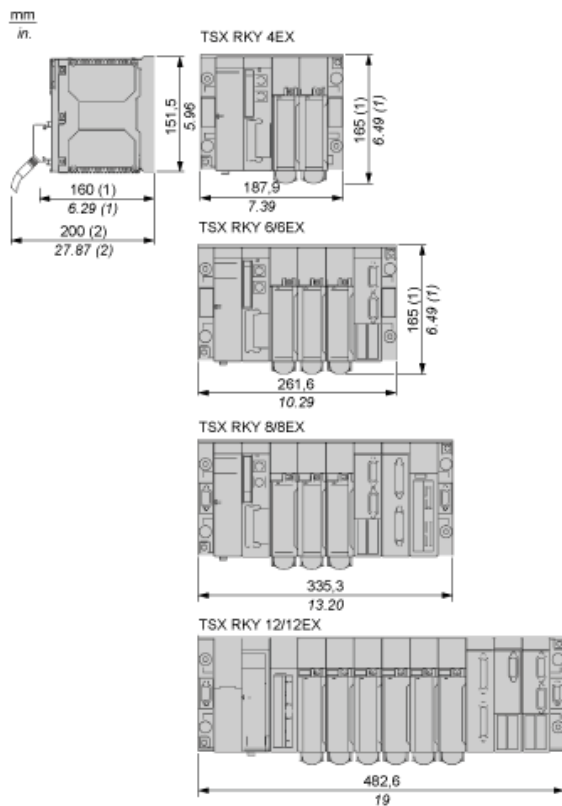

(1) With screw terminal block modules.

(2) Maximum depth for all types of modules and their associated connectors.

Connection of Speed Reference Signals

Connector Pinout

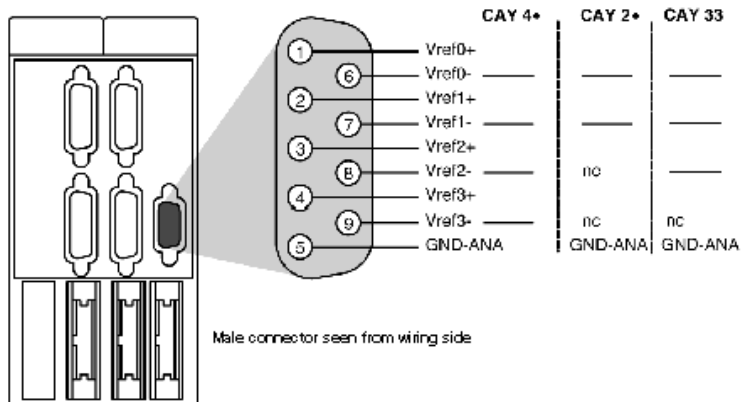

Connection of Counting Signals

Connectors Pinouts

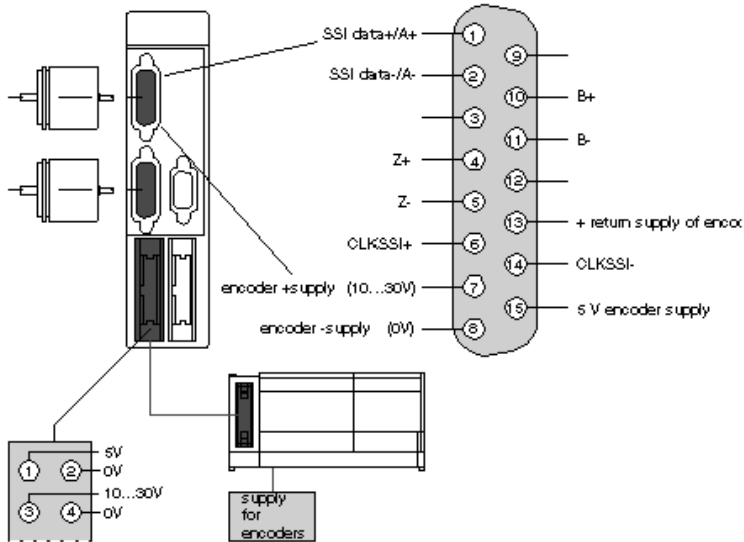

Element	Designation	Terminal
Incremental encoder	input A+	1
	input A-	2
	input Z+	4
	input Z-	5
	input B+	10
	input B-	11
	return supply of encoder	13
Absolute SSI encoder:	+ SSI Data	1
	- SSI data	2
	CLKSSI+	6
	CLKSSI-	14
5 V encoder power supply	+supply (5 V)	15
	- supply (0 V)	8
Encoder power supply (10-30 V)	+supply (10-30 V)	7
	- supply (0 V)	8

Connection of Sensors/Pre-actuators and Encoder Power Supply, without Variable Speed Controller

HE10 Connector Pinout

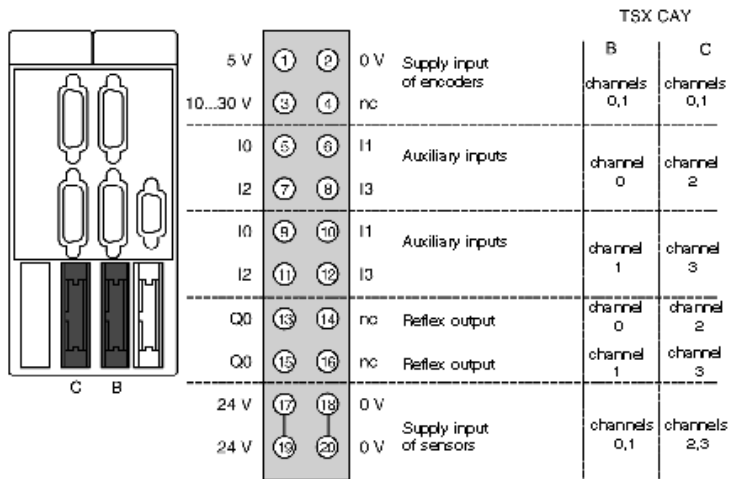

TSX CAY 2* module: Channels 0 and 1
 TSX CAY 4* module: Channels 0,1,2 and 3
 TSX CAY 33* module: Channels 0,1 and 2

The auxiliary inputs/outputs are allocated the following functions:

- I0 = cam reference point input,
- I1 = emergency stop input (stop if there is no current in the input),
- I2 = adjusting input,
- I3 = adjustment input,
- Q0 = reflex output (static output),
- 0 V = shared auxiliary inputs and reflex outputs.

Connection of the Variable Speed Controller Signals

Connector Pinout

The axis command modules implement basic management of the signals necessary for correct operation of the variable speed controllers. There is only one connector, regardless of the number of axis command module channels.

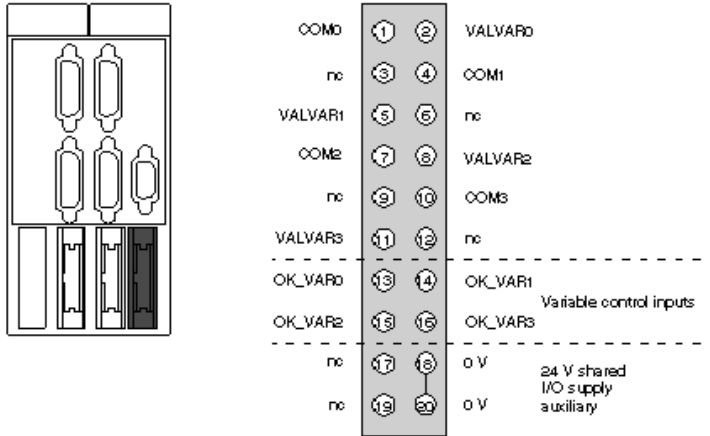

COMx – VALVARx: potential free contact to validate variable speed controller

OK_VARx: variable speed controller input check

24 V – 0 V sensor power supply

NOTE: Each channel uses a potential free closing contact.