

ATV930U07N4

variable speed drive - ATV930 - 0,75kW -
400/480V - with braking unit - IP21

Product availability : Non-Stock - Not normally stocked in distribution facility



Price* : 1,246.00 USD



Main

Range of product	Altivar Process ATV900
Product or component type	Variable speed drive
Device application	Industrial application
Device short name	ATV930
Variant	Standard version With braking chopper
Product destination	Synchronous motors Asynchronous motors
Mounting mode	Wall mount
EMC filter	Integrated conforming to EN/IEC 61800-3 category C3 with <= 150 m motor cable maxi Integrated conforming to EN/IEC 61800-3 category C2 with <= 50 m motor cable maxi
IP degree of protection	IP21 conforming to IEC 61800-5-1 IP21 conforming to IEC 60529
Degree of protection	UL type 1 conforming to UL 508C
Type of cooling	Forced convection
Supply frequency	50...60 Hz (+/- 5 %)
Network number of phases	3 phases
[Us] rated supply voltage	380...480 V (- 15...10 %)
Motor power kW	0.75 kW (normal duty) 0.37 kW (heavy duty)
Motor power hp	1 hp (normal duty) 0.5 hp (heavy duty)
Line current	1.5 A at 380 V (normal duty) 1.3 A at 480 V (normal duty) 0.9 A at 380 V (heavy duty) 0.8 A at 480 V (heavy duty)
Prospective line I _{sc}	50 kA
Apparent power	1.1 kVA at 480 V (normal duty) 0.7 kVA at 480 V (heavy duty)

Disclaimer: This documentation is not intended as a substitute for and is not to be used for determining suitability or reliability of these products for specific user applications

Continuous output current	2.2 A at 4 kHz (normal duty) 1.5 A at 4 kHz (heavy duty)
Maximum transient current	2.6 A during 60 s (normal duty) 2.3 A during 60 s (heavy duty)
Asynchronous motor control profile	Optimized torque mode Constant torque standard Variable torque standard
Synchronous motor control profile	Permanent magnet motor Synchronous reluctance motor
Speed drive output frequency	0.1...599 Hz
Nominal switching frequency	4 kHz
Switching frequency	2...16 kHz adjustable 4...16 kHz with derating factor
Safety function	STO (safe torque off) SIL 3
Number of preset speeds	16 preset speeds
Communication port protocol	Modbus serial Modbus TCP Ethernet/IP
Option module	Slot A: communication module Profibus DP V1 Slot A: communication module Profinet Slot A: communication module DeviceNet Slot A: communication module CANopen daisy chain RJ45 Slot A: communication module CANopen SUB-D 9 Slot A: communication module CANopen screw terminals Slot A: communication module EtherCAT Slot A/slot B/slot C: digital and analog I/O extension module Slot A/slot B/slot C: output relay extension module Slot B: 5/12 V digital encoder interface module Slot B: analog encoder interface module Slot B: resolver encoder interface module Communication module for Ethernet Powerlink

Complementary

Output voltage	<= power supply voltage
Motor slip compensation	Automatic whatever the load Adjustable Can be suppressed Not available in permanent magnet motor law
Acceleration and deceleration ramps	Linear adjustable separately from 0.01...9999 s
Braking to standstill	By DC injection
Protection type	Motor: thermal protection Motor: safe torque off Motor: motor phase break Drive: thermal protection Drive: safe torque off Drive: overheating Drive: overcurrent between output phases and earth Drive: overload of output voltage Drive: short-circuit protection Drive: motor phase break Drive: overvoltages on the DC bus Drive: line supply overvoltage Drive: line supply undervoltage Drive: line supply phase loss Drive: overspeed Drive: break on the control circuit
Frequency resolution	Display unit: 0.1 Hz Analog input: 0.012/50 Hz
Electrical connection	Control, screw terminal: 0.5...1.5 mm ² (AWG 20...AWG 16) DC bus, screw terminal: 2.5...6 mm ² (AWG 14...AWG 10) Line side, screw terminal: 2.5...6 mm ² (AWG 14...AWG 10) Motor, screw terminal: 2.5...6 mm ² (AWG 14...AWG 10)
Connector type	2 RJ45 (on the control block) Ethernet IP/Modbus TCP 1 RJ45 (on the control block) Modbus serial
Physical interface	2-wire RS 485 Modbus serial

Transmission frame	RTU Modbus serial
Transmission rate	10/100 Mbit/s Ethernet IP/Modbus TCP 4.8, 9.6, 19.2, 38.4 kbit/s for Modbus serial
Exchange mode	Half duplex, full duplex, autonegotiation Ethernet IP/Modbus TCP
Data format	8 bits, configurable odd, even or no parity Modbus serial
Type of polarization	No impedance Modbus serial
Number of addresses	1...247 Modbus serial
Method of access	Slave Modbus TCP
Supply	External supply for digital inputs: 24 V DC (19...30 V) current \leq 1.25 mA (overload and short-circuit protection) Internal supply for reference potentiometer (1 to 10 kOhm): 10.5 V DC \pm 5 % current \leq 10 mA (overload and short-circuit protection) Internal supply for digital inputs and STO: 24 V DC (21...27 V) current \leq 200 mA (overload and short-circuit protection)
Local signalling	3 mono/dual colour LED for local diagnostic 5 dual colour LED for embedded communication status 2 dual colour LED for communication module status 1 red LED for presence of voltage
Width	5.67 in (144 mm)
Height	13.78 in (350 mm)
Depth	8.11 in (206 mm)
Product weight	9.92 lb(US) (4.5 kg)
Analogue input number	3
Analogue input type	Software-configurable voltage AI1, AI2, AI3: 0...10 V DC impedance 30 kOhm, resolution 12 bits Software-configurable current AI1, AI2, AI3 : 0...20 mA/4...20 mA impedance 250 Ohm, resolution 12 bits
Discrete input number	10
Discrete input type	Programmable DI1...DI8: 24 V DC (\leq 30 V) impedance 3.5 kOhm Programmable as pulse input DI7, DI8 0...30 kHz: 24 V DC (\leq 30 V) Safe torque off STOA, STOB: 24 V DC (\leq 30 V) impedance $>$ 2.2 kOhm
Input compatibility	Discrete input STOA, STOB: level 1 PLC conforming to EN/IEC 61131-2 Discrete input DI1...DI8: level 1 PLC conforming to EN/IEC 61131-2 Pulse input DI7, DI8: level 1 PLC conforming to IEC 65A-68
Analogue output number	2
Discrete output number	2
Discrete output type	Logic output DQ+ : 0...1 kHz (\leq 30 V) DC, 100 mA Programmable as pulse output DQ+ : 0...30 kHz (\leq 30 V) DC, 20 mA Logic output DQ- : 0...1 kHz (\leq 30 V) DC, 100 mA
Sampling duration	Discrete input DI1...DI8: 2 ms (\pm 0.5 ms) Pulse input DI7, DI8: 5 ms (\pm 1 ms) Analog input AI1, AI2, AI3: 1 ms (\pm 1 ms) Analog output AQ1, AQ2: 5 ms (\pm 1 ms)
Accuracy	Analog input AI1, AI2, AI3: \pm 0.6 % for a temperature variation 60 °C Analog output AQ1, AQ2: \pm 1 % for a temperature variation 60 °C
Linearity error	Analog input AI1, AI2, AI3: \pm 0.15 % of maximum value Analog output AQ1, AQ2: \pm 0.2 %
Maximum switching current	Relay output R1 on inductive load ($\cos \phi = 0.4$ and $L/R = 7$ ms) : 2 A at 250 V AC Relay output R1 on inductive load ($\cos \phi = 0.4$ and $L/R = 7$ ms) : 2 A at 30 V DC Relay output R2, R3 on inductive load ($\cos \phi = 0.4$ and $L/R = 7$ ms) : 2 A at 250 V AC Relay output R2, R3 on inductive load ($\cos \phi = 0.4$ and $L/R = 7$ ms) : 2 A at 30 V DC Relay output R1 on resistive load ($\cos \phi = 1$) : 3 A at 250 V AC Relay output R1 on resistive load ($\cos \phi = 1$) : 3 A at 30 V DC Relay output R2, R3 on resistive load ($\cos \phi = 1$) : 5 A at 250 V AC Relay output R2, R3 on resistive load ($\cos \phi = 1$) : 5 A at 30 V DC
Relay output number	3
Relay output type	Configurable relay logic R1: fault relay NO/NC electrical durability 100000 cycles Configurable relay logic R2: sequence relay NO electrical durability 1000000 cycles Configurable relay logic R3: sequence relay NO electrical durability 1000000 cycles
Refresh time	Relay output R1, R2, R3: 5 ms (\pm 0.5 ms)
Minimum switching current	Relay output R1, R2, R3: 5 mA at 24 V DC
Isolation	Between power and control terminals
Specific application	Process

IP degree of protection	IP21
-------------------------	------

Environment

Insulation resistance	> 1 mOhm at 500 V DC for 1 minute to earth
Noise level	54.5 dB conforming to 86/188/EEC
Power dissipation in W	26 W (natural convection) at 380 V switching frequency 4 kHz 21 W (forced convection) at 380 V switching frequency 4 kHz
Vibration resistance	1.5 mm peak to peak (f = 2...13 Hz) conforming to IEC 60068-2-6 1 gn (f = 13...200 Hz) conforming to IEC 60068-2-6
Shock resistance	15 gn during 11 ms conforming to IEC 60068-2-27
Volume of cooling air	10038.72 Gal/hr(US) (38 m3/h)
Operating position	Vertical +/- 10 degree
THDI	<= 48 % full load conforming to IEC 61000-3-12
Electromagnetic compatibility	1.2/50 µs - 8/20 µs surge immunity test level 3 conforming to IEC 61000-4-5 Electrical fast transient/burst immunity test level 4 conforming to IEC 61000-4-4 Electrostatic discharge immunity test level 3 conforming to IEC 61000-4-2 Radiated radio-frequency electromagnetic field immunity test level 3 conforming to IEC 61000-4-3 Conducted radio-frequency immunity test level 3 conforming to IEC 61000-4-6
Pollution degree	2 EN/IEC 61800-5-1
Environmental characteristic	Chemical pollution resistance class 3C3 conforming to EN/IEC 60721-3-3 Dust pollution resistance class 3S3 conforming to EN/IEC 60721-3-3
Relative humidity	5...95 % without condensation conforming to IEC 60068-2-3
Ambient air temperature for operation	5...122 °F (-15...50 °C) without derating 122...140 °F (50...60 °C) with derating factor
Ambient air temperature for storage	-40...158 °F (-40...70 °C)
Operating altitude	1000...4800 m with current derating 1 % per 100 m <= 3280.84 ft (1000 m) without derating
Standards	EN/IEC 61800-3 UL 508C EN/IEC 61800-5-1 IEC 61000-3-12 IEC 60721-3 IEC 61508 IEC 13849-1 EN/IEC 61800-3 (environment 1 category C2) EN/IEC 61800-3 (environment 2 category C3)
Product certifications	TÜV UL CSA REACH
Marking	CE

Ordering and shipping details

Category	22276 - ATV930 FRAMES 1 & 2
Discount Schedule	CP4E
GTIN	00785901960577
Nbr. of units in pkg.	1
Package weight(Lbs)	12.800000000000001
Returnability	N
Country of origin	ID

Offer Sustainability

Sustainable offer status	Green Premium product
RoHS (date code: YYWW)	Compliant - since 1526 - Schneider Electric declaration of conformity Schneider Electric declaration of conformity
REACH	Reference not containing SVHC above the threshold Reference not containing SVHC above the threshold
Product environmental profile	Available

 Product Environmental Profile

Product end of life instructions	Available  End of Life Information
California proposition 65	WARNING: This product can expose you to chemicals including:
----- Substance 1	Lead and lead compounds, which is known to the State of California to cause cancer and birth defects or other reproductive harm.
----- Substance 2	Bisphenol A (BPA), which is known to the State of California to cause birth defects or other reproductive harm.
----- More information	For more information go to www.p65warnings.ca.gov

Dimensions

IP21 / UL Type 1 Drives - Right Side, Front and Rear View

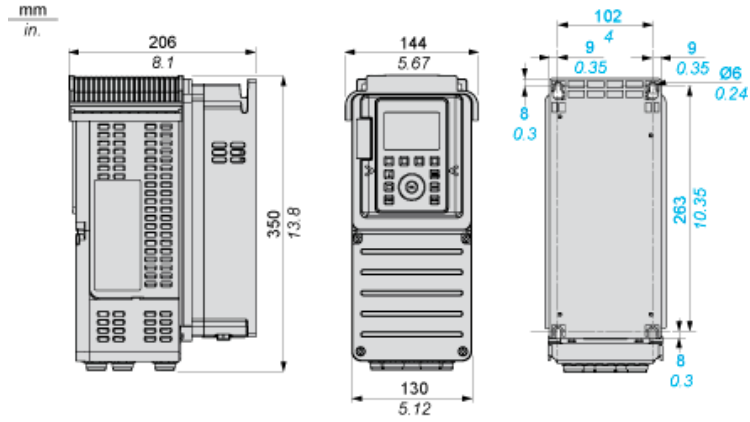

Clearances

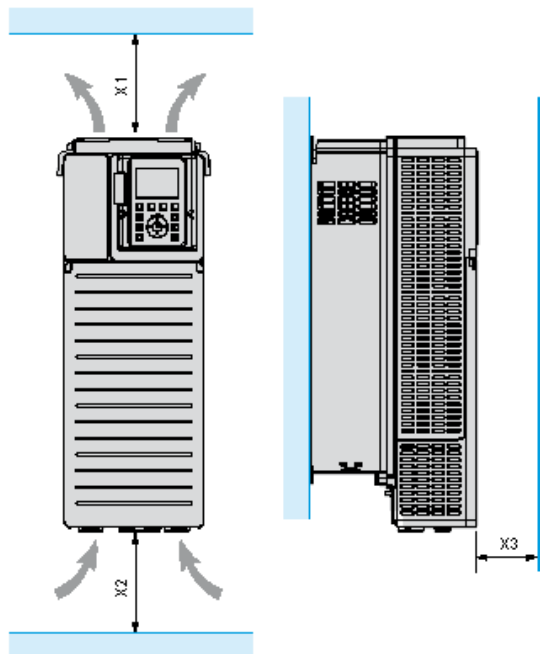

X1	X2	X3
≥ 100 mm (3.94 in.)	≥ 100 mm (3.94 in.)	≥ 10 mm (0.39 in.)

- Mount the device in a vertical position ($\pm 10^\circ$). This is required for cooling the device.
- Do not mount the device close to heat sources.
- Leave sufficient free space so that the air required for cooling purposes can circulate from the bottom to the top of the drive.

Mounting Types

Mounting Type A: Individual IP21

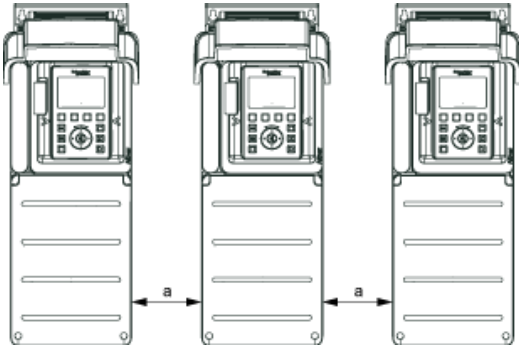

$a \geq 100 \text{ mm (3.94 in.)}$

Mounting Type B: Side by Side IP20

